

ELECTRICAL ENGINEERING

Paper – II

Time Allowed : **Three Hours**

Maximum Marks : **300**

Question Paper Specific Instructions

Please read each of the following instructions carefully before attempting questions :

*There are **EIGHT** questions divided in **TWO** sections.*

*Candidate has to attempt **FIVE** questions in all.*

*Questions No. **1** and **5** are **compulsory** and out of the remaining, **THREE** are to be attempted choosing at least **ONE** question from each Section.*

The number of marks carried by a question / part is indicated against it.

Wherever any assumptions are made for answering a question, they must be clearly indicated.

Diagrams / Figures, wherever required, shall be drawn in the space provided for answering the question itself.

Unless otherwise mentioned, symbols and notations have their usual standard meanings.

Attempts of questions shall be counted in sequential order. Unless struck off, attempt of a question shall be counted even if attempted partly.

Any page or portion of the page left blank in the Question-cum-Answer (QCA) Booklet must be clearly struck off.

*Answers must be written in **ENGLISH** only.*

SECTION A

12

- Q1. (a)** Draw the transfer characteristic of the circuit shown below :
Assume the op-amp to be ideal.

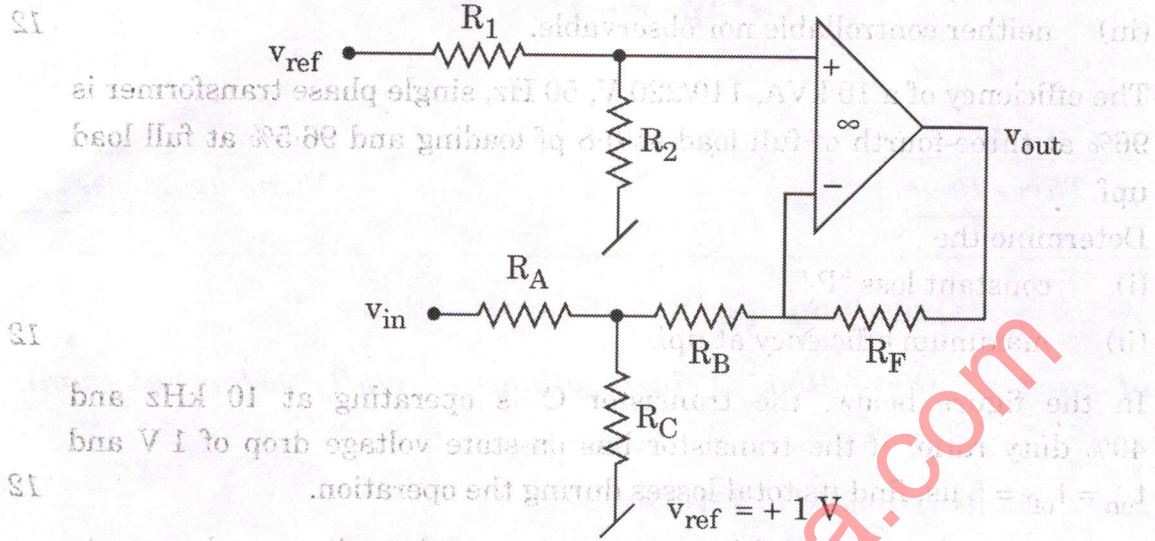

$$R_1 = R_2 = R_A = R_C = 100 \text{ k}\Omega$$

$$R_B = 50 \text{ k}\Omega, R_F = 1 \text{ M}\Omega$$

- (b) Let an analog filter have a transfer function

$$H(s) = \frac{s + 0.5}{(s + 0.5)^2 + 16}$$

Use bilinear transformation method to convert analog filter into a digital filter.

12

Assume the resonant frequency of $\omega_r = \frac{\pi}{2}$ for the digital IIR filter.

- (c) An LTI system is described by the following equations :

$$\dot{X} = AX + Bx$$

$$y = CX + Dx$$

$$\text{where } A = \begin{bmatrix} -2 & 0 & 0 & 0 \\ 0 & -1 & 0 & 0 \\ 0 & 0 & -5 & 0 \\ 0 & 0 & 0 & -3 \end{bmatrix}; \quad B = \begin{bmatrix} 1 \\ 1 \\ 0 \\ 0 \end{bmatrix};$$

$$C = [1 \ 0 \ 1 \ 0]; \quad D = 0.$$

Draw the block diagram of the system and therefrom, identify the state variable(s) that are

- (i) not controllable.
- (ii) not observable.
- (iii) neither controllable nor observable.

12

(d) The efficiency of a 10 kVA, 110/220 V, 50 Hz, single phase transformer is 96% at three-fourth of full load at 0.8 pf leading and 96.5% at full load upf.

Determine the

- (i) constant loss " P_i ".
- (ii) maximum efficiency at upf.

12

(e) In the figure below, the transistor Q is operating at 10 kHz and 40% duty ratio. If the transistor has on-state voltage drop of 1 V and $t_{on} = t_{off} = 5 \mu s$, find its total losses during the operation.

12

(Assume linear rise and fall characteristics of the voltage and currents in the device during switching)

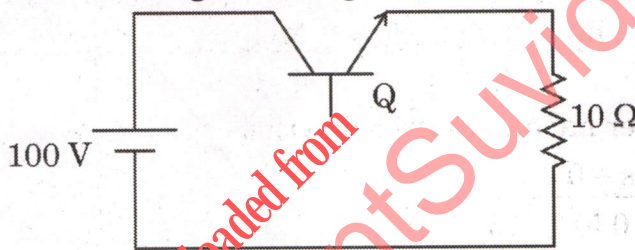

Q2. (a) (i) Determine the transfer function of the circuit shown below and determine therefrom, the function performed by the circuit. Also determine the input impedance $Z_{in}(s)$, as indicated in the figure.

12

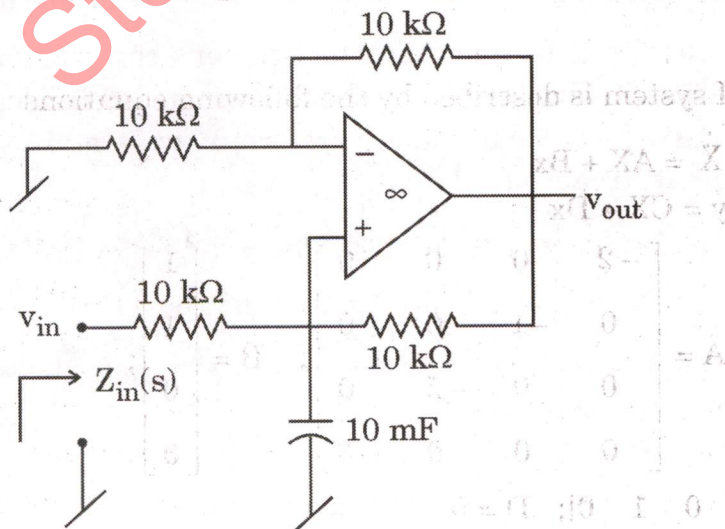

- (ii) The transfer function of a 2nd order filter has a zero at the origin of the s-plane while its poles are located at $s = -3 \pm j4$ rad/sec. Identify the filter, if the magnitude of the voltage gain at 5 rad/sec = 1. Also plot the magnitude of the voltage gain as the input signal frequency is varied between $\omega = 0$ to $\omega = \infty$.

8

- (b) Consider a mechanical vibratory system as shown in Figure (a) below. Two kilograms of force is applied to the system in the form of step input resulting in the oscillation of mass. Determine the system parameters m , b and k of the mechanical vibratory system if the step response curve obtained is as shown in Figure (b). Displacement 'x' may be measured from the equilibrium position.

20

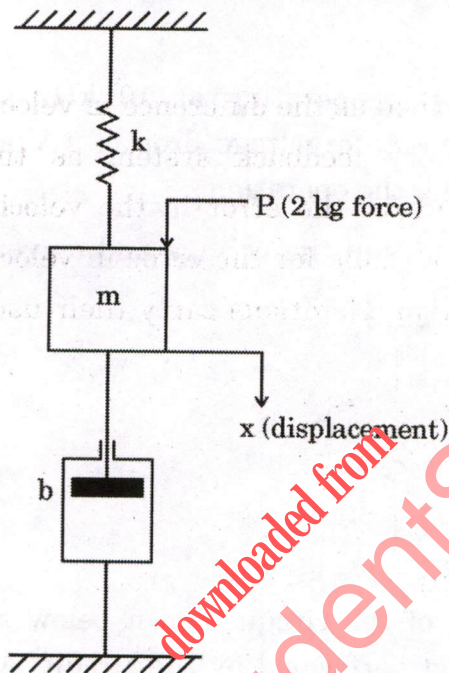

Figure (a)

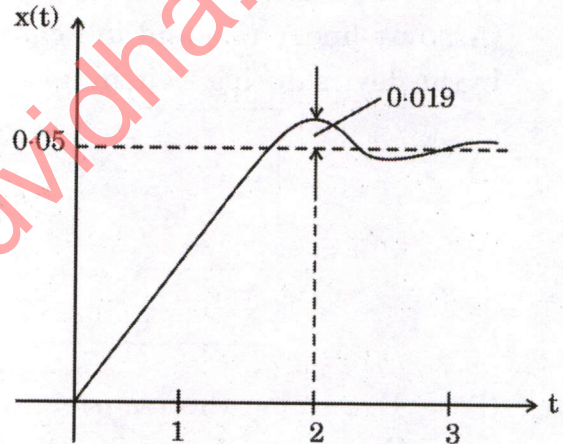

Figure (b)

- (c) Draw the Speed-Torque characteristics of a three-phase induction motor. A 3-phase, 50 Hz, 400 V, 8-pole, star-connected induction motor has the following circuit parameters referred to stator side in an exact equivalent circuit model :

$$R_1 = 0.21 \Omega, \quad R'_2 = 0.32 \Omega, \quad X_1 + X'_2 = 4.8 \Omega, \quad R_i = 138 \Omega, \quad X_m = 18.1 \Omega$$

Assuming $X_1 = X'_2$ and slip $S = 4\%$, find the

- (i) total impedance seen from stator side (per-phase).
- (ii) input line current.
- (iii) input power drawn.
- (iv) gross mechanical power developed.
- (v) gross torque developed.

20

Q3. (a) Consider the unilateral Laplace transform pair $\cos(2t) u(t) \xleftrightarrow{\mathcal{L}^u} X(s)$. Using the Laplace transform properties, determine the time signals corresponding to the following : 20

(i) $X(2s)$

(ii) $(s + 4) X(s)$

(iii) $\frac{d}{ds} (e^{-5s} X(s))$

(iv) $s^{-2} X(s)$

(b) Let the steady state velocity error be defined as the difference in velocity between input and output of the unity feedback system as time approaches infinity. Find the expression for the error in the velocity, $\dot{e}(\infty) = \dot{r}(\infty) - \dot{i}(\infty)$ and fill the following table for the error in velocity for different inputs in Type 0, 1, 2 system. Notations carry their usual meaning. 20

		Type		
		0	1	2
Input	Step			
	Ramp			
	Parabola			

(c) (i) What do you mean by Tuned Power Lines ? A 3-phase, 50 Hz, 500 kV, lossless transmission line is 600 km long. The line inductance is 1 mH/km/phase and capacitance is 10 nF/km/phase. Determine the phase constant β , surge impedance Z_c , velocity of propagation v , and line wavelength λ . 10

(ii) A 200 km long, 50 Hz, 3-phase transmission line has a total series impedance of $40 + j125 \Omega$ and shunt admittance of 10^{-3} S . It is feeding to a load of 62.5 MVA at 220 kV with 0.8 pf lagging. Find the sending end voltage, current and power factor using nominal π -method. 10

- Q4. (a)** A 240 V shunt motor takes a current of 3.5 A on no load. The armature resistance is of 0.4 Ω , and shunt field resistance of 160 Ω when motor operates at full load. It takes 24 A and runs at 2400 rpm when the motor is converted to long shunt compound type by adding a field winding of 0.1 Ω . There is a change of 10% in the total flux, when the compound motor develops the same torque. Determine the power developed and speed of the motor when it is connected as
- (i) a cumulative compound motor.
 - (ii) a differential compound motor.

20

- (b) What do you mean by the steady state stability limit of a power system? Find the steady state power limit of a power system consisting of a generator with equivalent reactance of 0.5 pu, connected to an infinite bus through a series reactance of 0.1 pu. The terminal voltage of the generator is held at 1.2 pu and the infinite bus voltage at 1.0 pu.

20

- (c) A single phase full bridge fully controlled converter is supplying a battery at 100 V for charging application. The converter is connected to 240 V, 50 Hz AC supply. The interconnecting inductor between converter and battery is very large to make the load current flat, continuous and ripple free at 10 A. The inductor has a resistance of 1.5 Ω . Find the

- (i) operating triggering angle.
- (ii) average and rms values of converter output voltage.
- (iii) power supplied to the battery.
- (iv) converter input power.
- (v) input power factor and displacement factor.
- (vi) thyristor rms current.

Draw source current, thyristor current and output voltage waveforms of the converter.

20

Assume a conduction voltage drop of 1.5 V for each thyristor.

SECTION B

Q5. (a) (i) Draw the truth table of the three input logic gate shown below :

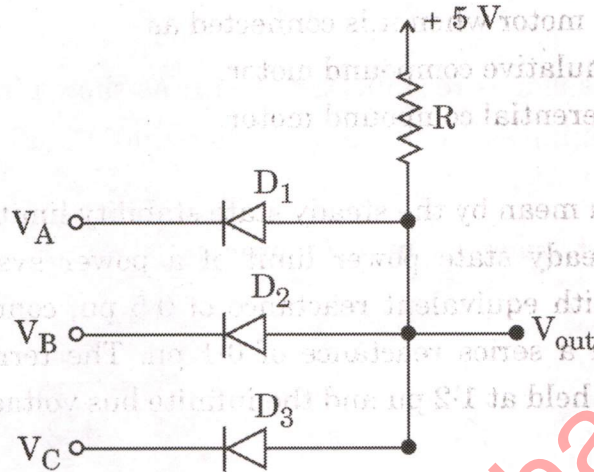

+ 5 V may be taken as logic '1' while 0 V may be taken as logic '0'.
The diodes D_1 , D_2 and D_3 are ideal diodes.

(ii) Given the logic function of three variables

$$f(A, B, C) = A + \bar{B}C$$

express it in the standard product-of-sum form.

(b) The characteristic equation of a unity feedback (negative) system is given by

$$s^3 + 3ks^2 + (k + 2)s + 4 = 0.$$

(i) Determine the forward path transfer function $G(s)$.

(ii) Using Routh-Hurwitz criteria, find the range of k for which the system is stable.

- (c) A star-delta transformer has delta side disconnected between A and D while supply is connected to the star side as shown in the Figure (a) below. An rms voltmeter between A and B reads 460 V under this condition. When A and D are connected, the same voltmeter between A and B reads 415 V. Find the voltage between A and D when they are disconnected.

Now the delta side is reconnected as star as shown in the Figure (b) with supply remaining the same on the other side. Find the voltages between P and N and between P and Q.

12

(Assume odd harmonics up to 7th order)

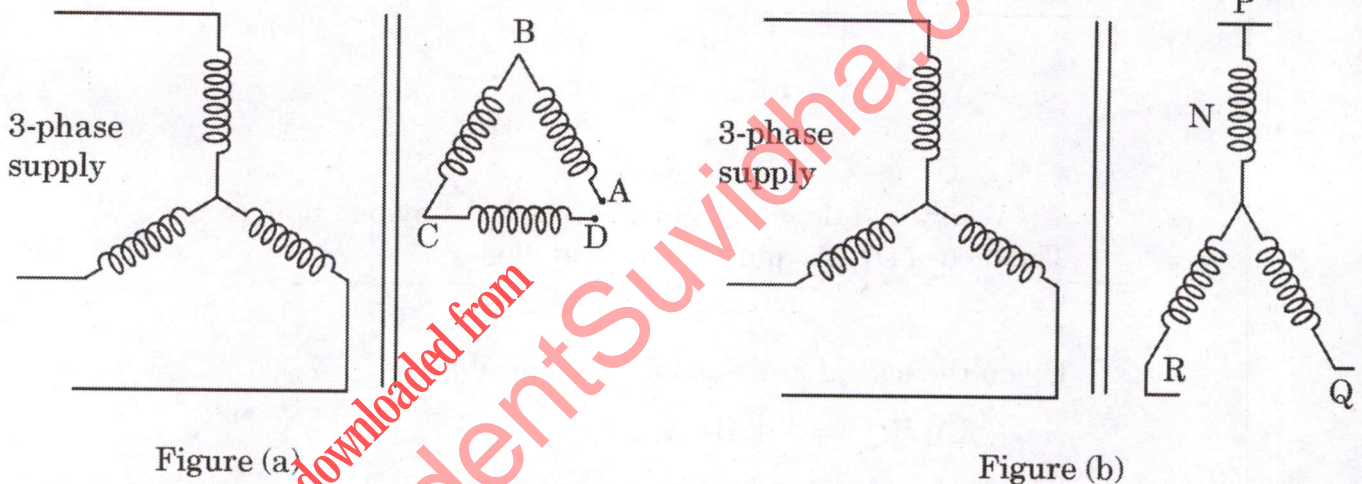

Figure (a)

Figure (b)

- (d) A three phase overhead transmission line in delta configuration is operating at 400 kV between phases at 50 Hz. The overall conductor diameter is 5.0 cm each. Find the allowable minimum spacing between the conductors to avoid corona loss under fair weather condition.

Also find the corona loss under stormy weather condition where the disruptive critical voltage reduces by 20%.

12

(Assume air density factor of 0.95, irregularity factor of 0.85 and disruptive critical voltage of 450 kV (L-L) under fair weather condition)

- (e) The configuration of a single phase bridge inverter is shown in the figure below. The DC source voltage is 100 V and the connected load is a pure inductor of 1 H. The switching frequency of the inverter is 50 Hz.

Determine

- (i) the maximum current through the transistors and diodes.
- (ii) the rms currents of the diodes and transistors.
- (iii) Sketch the load voltage and current waveforms indicating conducting devices.

12

(Assume ideal devices with no losses and square wave switching for the inverter)

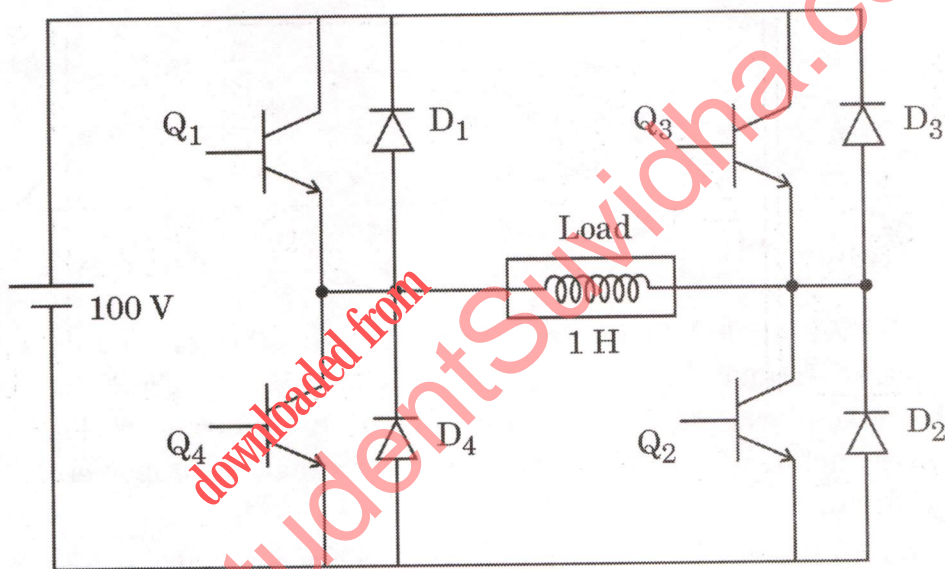

- Q6. (a) (i) A modulated signal is represented below as

$$e(t) = 1500 \sin (2\pi \times 10^9 t + 2 \sin \pi \times 10^4 t).$$

Determine the

- (1) type of modulation.
- (2) carrier frequency.
- (3) transmitted power, if the signal is applied to a 75 Ω antenna.
- (4) modulation index.
- (5) frequency deviation.

10

- (ii) Explain the mathematical function that is performed by the following instructions of 8085 microprocessor :

10

```
MVI A, 07H
RLC
MOV B, A
RLC
RLC
ADD B
```

- (b) Consider the trapezoidal function $x(t)$ as shown below. Express $x(t)$ in terms of ramp function and find its Fourier transform. Specify the Fourier transform property used (if any).

20

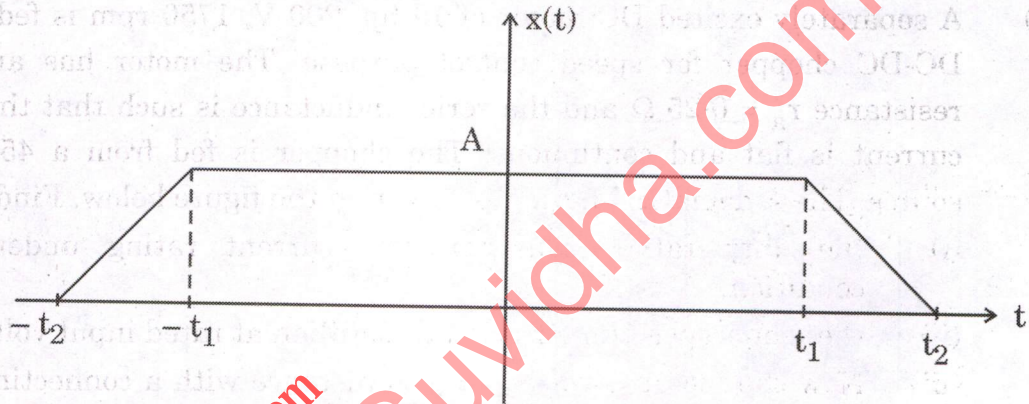

- (c) A 25 kVA, 2500 V/250 V two winding transformer is to be used as autotransformer with a source voltage of 2500 V. Find the maximum power that can be supplied by the autotransformer to load at unity power factor. Find the conducted and transformed power under this condition.

Also find the efficiency of the autotransformer at unity power factor and maximum output power condition if the efficiency of the single phase transformer at half load, 0.8 pf lag and rated voltage is 90%. Assume the no load losses for the single phase transformer as 500 W.

20

(Assume no core saturation of the transformer)

- Q7.** (a) The loop transfer function $G(s)H(s)$ of a single-feedback-loop control system is given by

$$G(s)H(s) = \frac{K}{s^2 (s + 2) (s + 10)}$$

Apply the Nyquist criterion and determine the value of K for the system to be stable. Also determine the gain margin if $K = 10$.

20

(b) Why are the load flow studies necessary in power system ?

For a 3-bus system as shown in the figure (data are given in table), construct the Y-bus.

20

Bus	Impedance Z_{ik} (pu)	Line charging $y'_{ik}/2$ (pu)
1 - 2	$0.02 + j0.06$	$j0.03$
1 - 3	$0.08 + j0.24$	$j0.025$
2 - 3	$0.06 + j0.18$	$j0.02$

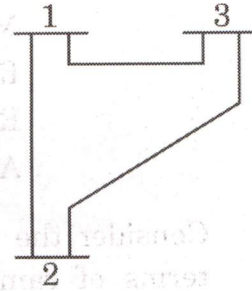

(c) A separately excited DC motor of 10 hp, 200 V, 1750 rpm is fed from a DC-DC chopper for speed control purpose. The motor has armature resistance $r_a = 0.25 \Omega$ and the series inductance is such that the motor current is flat and continuous. The chopper is fed from a 450 V DC source. The schematic diagram is shown in the figure below. Find

- the duty ratio, transistor rms current rating under rated condition.
- the motor speed under no load condition at rated input voltage.
- Now the motor is relocated at a distance with a connecting cable of 1.5Ω resistance and the speed is to be reduced to 1000 rpm at half-rated torque. Find the new duty ratio and converter output voltage.

20

Assume negligible device losses, a total brush drop of 3.0 V for the motor under operation and a 10 kHz switching frequency for the chopper.

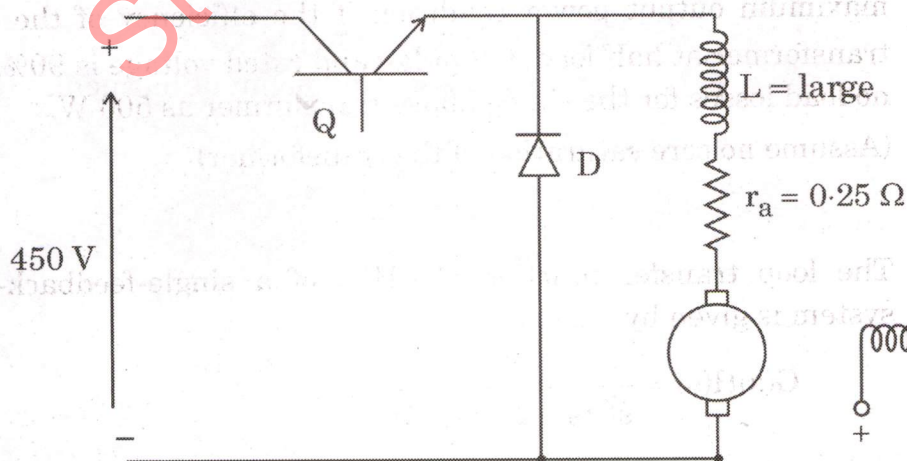

- Q8. (a) Consider the sequences $x(n) = \left(\frac{1}{2}\right)^n u(n)$ and $y(n) = \left(\frac{1}{3}\right)^{n-2} u(n-2)$.

Use the convolution property of Z-transform to find the convolution of the two sequences, $q(n) = x(n) * y(n)$. Validate your result using time-domain method of convolution.

20

- (b) A 6.6 kV star-connected synchronous motor has synchronous impedance $Z_s = (2 + j10) \Omega$ per phase. Its excitation is so adjusted that for an input power of 500 kW, the motor pf is 0.7 leading. Now the motor is connected in parallel with a load drawing 1000 kW power at 0.8 pf lag while its input power is changed to 600 kW with same excitation as above.

Find

- (i) the new load angle of the motor.
 - (ii) the total input power factor for the load and synchronous motor combination.
- (c) A 3-phase, star-connected, 4-pole, 415 V, 50 Hz induction motor has equivalent circuit parameters of $R_s = 1.1 \Omega$, $R_r = 0.9 \Omega$, $X_{ls} = X_{lr} = 2.7 \Omega$ and $X_m = 67 \Omega$, all referred from stator side. The motor is driving a load whose torque is proportional to square of speed. For a load torque of 35 N-m the speed is 1440 rpm in the load characteristics. The motor is supplied from a three phase PWM inverter and the speed control is achieved through voltage control method. Now, if the motor speed is to be brought down to 1250 rpm, find the
- (i) load torque.
 - (ii) inverter applied voltage.
 - (iii) motor input current and power factor.
 - (iv) motor input power.
 - (v) motor developed output power.
- (Assume negligible no load losses and no input harmonics to the motor)

20

20